

THE PRESBYTERIAN CHURCH OF CHESTNUT HILL

An inclusive community of faith

Saturday, February 28, 2026

4 p.m.

A Service for the
Ordination and Installation of
Emily Chapdelaine
as Associate Minister at the
Presbyterian Church of Chestnut Hill

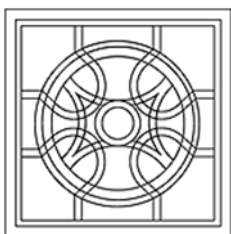
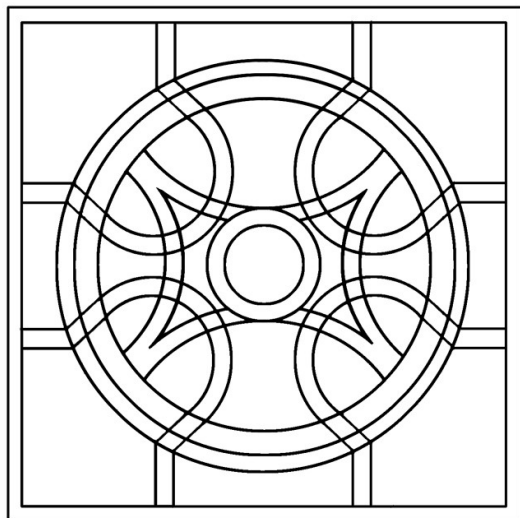

8855 Germantown Avenue, Philadelphia, Pennsylvania

ORDER OF WORSHIP

OPENING VOLUNTARY

INTROIT

Laudamus te from Mass in C minor

W. A. Mozart
(1756-1791)

*Laudamus te, benedicimus te,
adoramus te, glorificamus te.
Gratias agimus tibi
propter magnam gloriam tuam.*

We praise you, we bless you,
we adore you, we glorify you.
We give you thanks
for your great glory.

WELCOME

*CALL TO WORSHIP *(in unison)*

Leader: Almighty and eternal God,
by your grace you have called us to this time and place.
People: **To be your servant people as we follow our servant Lord.**
Leader: Make your Holy Spirit move within and among us,
People: **that together we may live a new life in the crucified and risen Christ.**
Leader: Bind us together in faith,
People: **so that as we receive all spiritual gifts needed to fulfill our calling,
we may support one another in our common ministry.**

Let Us Build a House
All Are Welcome

Capo 3: (A7) (D) (A) (D) (G) (A) (Bm)
C7 F C F B^b C Dm

1 Let us build a house where love can dwell and all can
2 Let us build a house where proph - ets speak, and words are
3 Let us build a house where love is found in wa - ter,
4 Let us build a house where hands will reach be - yond the
5 Let us build a house where all are named, their songs and

(D) (A) (D) (Bm7) (Em) (A)
F C F Dm7 Gm C

safe - ly live, a place where saints and chil - dren tell
strong and true, where all God's chil - dren dare to seek
wine, and wheat; a ban - quet hall on ho - ly ground
wood and stone to heal and strength-en, serve and teach,
vi - sions heard and loved and trea - sured, taught and claimed

(Em) (A7) (G) (D) (F#m) (Bm)
Gm C7 B^b F Am Dm

how hearts learn to for - give. Built of hopes and dreams and
to dream God's reign a - new. Here the cross shall stand as
where peace and jus - tice meet. Here the love of God, through
and live the Word they've known. Here the out - cast and the
as words with - in the Word. Built of tears and cries and

(Em) (A) (D) (G)
Gm C F B^b

vi - sions, rock of faith and vault of grace; here the
wit - ness and as sym - bol of God's grace; here as
Je - sus, is re - vealed in time and space; as we
strang - er bear the im - age of God's face; let us
laugh - ter, prayers of faith and songs of grace; let this

(D) (G) (F#7) (Bm) *Refrain* (Em) (Bm)
F B^b A7 Dm Gm Dm

love of Christ shall end di - vi - sions:
one we claim the faith of Je - sus:
share in Christ the feast that frees us: all are wel - come;
bring an end to fear and dan - ger:
house pro-claim from floor to raf - ter:

(F#m) (Em) (D) (Em) (A7) (D) (G) (D)
Am Gm F Gm C7 F B^b F

all are wel - come; all are wel - come in this place.

*Please stand as you are able.

PRAYER OF CONFESSION *(in unison)*

Lord of all, you call us to seek justice,
but we turn a blind eye to injustices in our midst.
You call us to love mercy,
but we celebrate cruelty in our world.
You call us to walk humbly with you, our God,
but we have strayed from the path that leads to you.
We have failed to see you in the face of the stranger,
the displaced, and the forgotten.
Forgive us, God, for the ways that we have failed
to love our neighbors and ourselves.
Make us whole, in one another and in you.
Teach us, prepare us, to walk in the ways of Christ,
that we, too, may bring heaven to earth.

SILENT CONFESSION

KYRIE ELEISON

Healey Willan
(1880-1968)

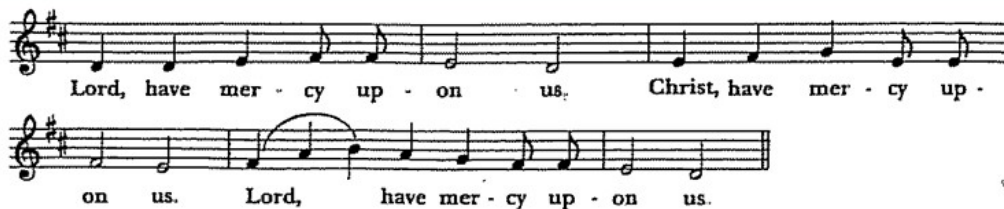

Lord, have mer - cy up - on us. Christ, have mer - cy up -
on us. Lord, have mer - cy up - on us.

PROMISE OF THE GOSPEL

Leader: Friends, believe the good news.
People: In Jesus Christ, we are forgiven.

*GLORIA PATRI

Henry W. Greatorex
(1816-1858)

The musical score is written for two staves, Treble and Bass clef, in 4/4 time with a key signature of two flats (B-flat and E-flat). The lyrics are: "Glo - ry be to the Fa - ther, and to the Son, and to the Ho - ly Ghost; As it was in the be - gin - ning, is now, and ev - er shall be, world with - out end. A - men, A - men." The melody is primarily composed of quarter and eighth notes, with some rests. The bass line provides a steady accompaniment with chords and single notes.

PRAYER FOR ILLUMINATION (*in unison*)

Send us your Holy Spirit, O God,
that these words might speak to us as your word,
and that our lives might bear witness
to the good news of Jesus Christ our Lord. Amen.

OLD TESTAMENT

Deuteronomy 26:16-19

“This very day the LORD your God is commanding you to observe these statutes and ordinances, so observe them diligently with all your heart and with all your soul. Today you have obtained the LORD’s agreement: to be your God; and for you to walk in his ways, to keep his statutes, his commandments, and his ordinances, and to obey him. Today the LORD has obtained your agreement: to be his treasured people, as he promised you, and to keep all his commandments; for him to set you high above all nations that he has made, in praise and in fame and in honor; and for you to be a people holy to the LORD your God, as he promised.”

Leader: Holy wisdom, Holy word.

People: Thanks be to God.

GOSPEL

Matthew 5:43-48

“You have heard that it was said, ‘You shall love your neighbor and hate your enemy.’ But I say to you: Love your enemies and pray for those who persecute you, so that you may be children of your Father in heaven, for he makes his sun rise on the evil and on the good and sends rain on the righteous and on the unrighteous. For if you love those who love you, what reward do you have? Do not even the tax collectors do the same? And if you greet only your brothers and sisters, what more are you doing than others? Do not even the gentiles do the same? Be perfect, therefore, as your heavenly Father is perfect.

Leader: Holy wisdom, Holy word.

People: Thanks be to God.

SERMON

Nobody Really Needs A Perfect Pastor

Andrew Pomerville

*HYMN 374

Lord, Make Us Servants of Your Peace

DICKINSON COLLEGE

*AFFIRMATION OF FAITH (*in unison*)

from A Brief Statement of Faith

We trust in God the Holy Spirit
everywhere the giver and renewer of life.
The Spirit justifies us by grace through faith,
sets us free to accept ourselves and to love God and neighbor,
and binds us together with all believers
in the one body of Christ, the Church.
The same Spirit
who inspired the prophets and apostles
rules our faith and life in Christ through Scripture,
engages us through the Word proclaimed,
claims us in the waters of baptism,
feeds us with the bread of life and the cup of salvation,
and calls women and men to all ministries of the Church.
In a broken and fearful world
the Spirit gives us courage
to pray without ceasing,
to witness among all peoples to Christ as Lord and Savior,
to unmask idolatries in Church and culture,
to hear the voices of peoples long silenced,
and to work with others for justice, freedom, and peace.
In gratitude to God, empowered by the Spirit,
we strive to serve Christ in our daily tasks
and to live holy and joyful lives,
even as we watch for God's new heaven and new earth,
praying, "Come, Lord Jesus!"

OFFERING

OFFERTORY ANTHEM

Ubi caritas et amor

Maurice Duruflé
(1902-1986)

<i>Ubi caritas et amor, Deus ibi est.</i>	Where charity and love are, God is there.
<i>Congregavit nos in unum Christi amor.</i>	The love of Christ has gathered us into one.
<i>Exsulemus, et in ipso iucundemur.</i>	Let us rejoice and be pleased in him.
<i>Timeamus, et amemus Deum vivum.</i>	Let us fear, and let us love the living God.
<i>Et ex corde diligamus nos sincero.</i>	And may we love each other with a sincere heart.
<i>Amen.</i>	<i>Amen.</i>

***PRAYER OF THANKSGIVING** (*in unison*)

Leader: The Lord be with you.

People: And also with you.

Leader: Let us pray.

All: Blessed are you, Maker of all things.

**Use what we have returned to you
to sow your love in our communities
through the one who gave himself for us. Amen.**

SERVICE OF ORDINATION AND INSTALLATION

WORDS OF INTRODUCTION

Jim Ballangee

CONSTITUTIONAL QUESTIONS TO THE CANDIDATE

Do you trust in Jesus Christ your Savior, acknowledge him Lord of all and Head of the Church, and through him believe in one God, Father, Son, and Holy Spirit?

Do you accept the Scriptures of the Old and New Testaments to be, by the Holy Spirit, the unique and authoritative witness to Jesus Christ in the Church universal, and God's Word to you?

Do you sincerely receive and adopt the essential tenets of the Reformed faith as expressed in the confessions of our church as authentic and reliable expositions of what Scripture leads us to believe and do, and will you be instructed and led by those confessions as you lead the people of God?

Will you fulfill your ministry in obedience to Jesus Christ, under the authority of Scripture, and be continually guided by our confessions?

Will you be governed by our church's polity, and will you abide by its discipline?

Will you be a friend among your colleagues in ministry, working with them, subject to the ordering of God's Word and Spirit?

Will you in your own life seek to follow the Lord Jesus Christ, love your neighbors, and work for the reconciliation of the world?

Do you promise to further the peace, unity, and purity of the church?

Will you pray for and seek to serve the people with energy, intelligence, imagination, and love?

CONSTITUTIONAL QUESTIONS TO THE CONGREGATION William Storm

Leader: Do we, the members of the church, accept Emily Chapdelaine as our associate pastor, chosen by God through the voice of this congregation to guide us in the way of Jesus Christ?

Congregation: We do.

Leader: Do we agree to pray for her, to encourage her, to respect her decisions, and to follow as she guides us, serving Jesus Christ, who alone is Head of the Church?

Congregation: We do.

Leader: Do we promise to pay her fairly and provide for her welfare as she works among us; to stand by her in trouble and share her joys? Will we listen to the Word she preaches, welcome her pastoral care, and honor her authority as she seeks to honor and obey Jesus Christ our Lord?

Congregation: We do and we will.

PRAYER OF ORDINATION

DECLARATION OF ORDINATION

CHARGE TO THE NEWLY ORDAINED

Andrew Chapdelaine

CHARGE TO THE CONGREGATION

Ellen Williams Hensle

***HYMN 332**

Live Into Hope

TRURO

BENEDICTION

Emily Chapdelaine

CLOSING VOLUNTARY

WORSHIP LEADERS:

PREACHING

Rev. Dr. Andrew Pomerville, he/him, *President of Louisville Presbyterian Theological Seminary,
Mid Kentucky Presbytery*

COMMISSION

Elder Jim Ballangee, he/him, *Moderator Designee, Arch Street Presbyterian Church*

Rev. Tamarah Lee, they/them, *Board Certified Chaplain, Presbytery of Philadelphia*

Rev. Ellen Williams Hensle, she/her, *Senior Minister and Head of Staff, Presbyterian Church of
Chestnut Hill*

Elder Elaine McCray, she/her, *Holy Trinity-Bethlehem Presbyterian Church*

Elder Nancy Pinkowicz, she/her, *Carmel Presbyterian Church*

SERVICE PARTICIPANTS

Rev. Andrew Chapdelaine, he/him, *Christ's Community Church*

Elder Stephen Hicks, he/him, *Covenant Presbyterian Church, Charlotte NC*

Elder William Storm, he/him, *Presbyterian Church of Chestnut Hill*

MUSIC

Jeffrey DeVault, *Organist*

Katy Avery, *Soprano*

MUSIC AND TEXTS Reprinted and streamed with permission under One License #A-743217. All Rights Reserved. *All Are Welcome*, text and music by: Marty Haugen, copyright 1994, GIA Publications, Inc. All rights reserved.

CHURCH STAFF

The Rev. Ellen Williams Hensle Senior Minister and Head of Staff

The Rev. Emily Chapdelaine Associate Minister for Congregational Life

The Rev. Cynthia A. Jarvis Pastor Emerita

Dr. Daniel Spratlan Director of Music

Jeffrey DeVault Organist and Associate Director of Music

Dr. Julie Snyder Director, Children's Education, Joyful Noise, and Youth Choir

Rachel Cline Church Administrator

Megan Cullen Director, Preschool

Mariangela Saavedra Director, Center on the Hill

Mary Frommer Office and Media Coordinator

Felix Delgado Full Time Sexton

Nakeem Coleman Part Time Sexton

Debbie Lambeth Sunday Child Care Giver



PCCH links and
online giving options

WE ARE A MATTHEW 25 CONGREGATION



PCCH is a Matthew 25 Congregation of the Presbyterian Church (USA). We are committed to building congregational vitality, dismantling structural racism, and eradicating systemic poverty. Scan the QR code to learn more.



CONTACT PCCH

Church office 215.247.8855

Preschool 215.247.8865

Center on the Hill 215.247.4654



info@chestnuthillpres.org



chestnuthillpres.org



PCCHestnuthill



chestnuthillpres.org/live